

# **IEEE Recommended Practice for Maintenance, Testing, and Replacement of Vented Lead-Acid Batteries for Stationary Applications**

Sponsor  
**Energy Development and Power Generation Committee  
of the  
IEEE Power Engineering Society**

Approved January 24, 1995  
**IEEE Standards Board**

**Abstract:** Maintenance, test schedules, and testing procedures that can be used to optimize the life and performance of permanently installed, vented lead-acid storage batteries used for standby power applications are provided. This recommended practice also provides guidance to determine when batteries should be replaced. This recommended practice is applicable to all stationary applications. However, specific applications, such as emergency lighting units and semiportable equipment, may have other appropriate practices and are beyond the scope of this recommended practice.

**Keywords:** acceptance test, battery capacity, battery installation, battery maintenance, battery replacement criteria, battery service test, battery terminal voltage, connection resistance readings, electrolyte level, equalize charge, float voltage, modified performance test, performance test, service test, specific gravity, standby power applications, state of charge, test discharge rate, vented lead-acid battery

---

The Institute of Electrical and Electronics Engineers, Inc.  
345 East 47th Street, New York, NY 10017-2394, USA  
Copyright © 1995 by the Institute of Electrical and Electronics Engineers, Inc.  
All rights reserved. Published 1995. Printed in the United States of America.  
ISBN 1-55937-515-9

*No part of this publication may be reproduced in any form, in an electronic retrieval system or otherwise, without the prior written permission of the publisher.*

**IEEE Standards** documents are developed within the Technical Committees of the IEEE Societies and the Standards Coordinating Committees of the IEEE Standards Board. Members of the committees serve voluntarily and without compensation. They are not necessarily members of the Institute. The standards developed within IEEE represent a consensus of the broad expertise on the subject within the Institute as well as those activities outside of IEEE that have expressed an interest in participating in the development of the standard.

Use of an IEEE Standard is wholly voluntary. The existence of an IEEE Standard does not imply that there are no other ways to produce, test, measure, purchase, market, or provide other goods and services related to the scope of the IEEE Standard. Furthermore, the viewpoint expressed at the time a standard is approved and issued is subject to change brought about through developments in the state of the art and comments received from users of the standard. Every IEEE Standard is subjected to review at least every five years for revision or reaffirmation. When a document is more than five years old and has not been reaffirmed, it is reasonable to conclude that its contents, although still of some value, do not wholly reflect the present state of the art. Users are cautioned to check to determine that they have the latest edition of any IEEE Standard.

Comments for revision of IEEE Standards are welcome from any interested party, regardless of membership affiliation with IEEE. Suggestions for changes in documents should be in the form of a proposed change of text, together with appropriate supporting comments.

Interpretations: Occasionally questions may arise regarding the meaning of portions of standards as they relate to specific applications. When the need for interpretations is brought to the attention of IEEE, the Institute will initiate action to prepare appropriate responses. Since IEEE Standards represent a consensus of all concerned interests, it is important to ensure that any interpretation has also received the concurrence of a balance of interests. For this reason IEEE and the members of its technical committees are not able to provide an instant response to interpretation requests except in those cases where the matter has previously received formal consideration.

Comments on standards and requests for interpretations should be addressed to:

Secretary, IEEE Standards Board  
445 Hoes Lane  
P.O. Box 1331  
Piscataway, NJ 08855-1331  
USA

IEEE Standards documents may involve the use of patented technology. Their approval by the Institute of Electrical and Electronics Engineers does not mean that using such technology for the purpose of conforming to such standards is authorized by the patent owner. It is the obligation of the user of such technology to obtain all necessary permissions.
-------------------------------------------------------------------------------------------------------------------------------------------------------------------------------------------------------------------------------------------------------------------------------------------------------------------------------------------------------------------

## Introduction

(This introduction is not a part of IEEE Std 450-1995, IEEE Recommended Practice for Maintenance, Testing, and Replacement of Vented Lead-Acid Batteries for Stationary Applications.)

Stationary lead-acid batteries play an ever increasing role in industry today by providing normal control and instrumentation power and backup energy for emergencies. This recommended practice fulfills the need within the industry to provide common or standard practices for battery maintenance, testing, and replacement. The methods described are applicable to all installations and battery sizes using vented lead-acid batteries.

The installations considered herein are designed for full-float operation with a battery charger serving to maintain the battery in a charged condition as well as to supply the normal dc load.

This recommended practice may be used separately, and when combined with IEEE Std 484-1987, IEEE Recommended Practice for Installation Design and Installation of Large Lead Storage Batteries for Generating Stations and Substations, and IEEE Std 485-1983, IEEE Recommended Practice for Sizing Large Lead Storage Batteries for Generating Stations and Substations, will provide the user with a general guide to sizing, designing, placing in service, maintaining, and testing a vented lead-acid storage battery installation. IEEE Std 535-1986, IEEE Standard for Qualification of Class 1E Lead Storage Batteries for Nuclear Power Generating Stations, is a companion document.

This recommended practice was prepared by the Working Group on Batteries, Station Design Subcommittee of the Energy Development and Power Generation Committee of the IEEE Power Engineering Society. At the time this recommended practice was completed, the Working Group on Batteries had the following membership:

**Robert R. Beavers, *Chair***

Wallace B. Bates  
Ladislav F. Bednar  
Jack H. Bellack  
Richard V. Biagetti  
Richard T. Bolgeo\*  
William B. Cantor  
Jay L. Chamberlin  
Joseph A. Cristino  
Peter J. DeMar  
Ramesh Desai  
David O. Feder  
Robert J. Fletcher  
Kyle D. Floyd  
James G. Godby  
John W. Gourdier  
Richard A. Greco

Paul E. Hellen  
Mark J. Hlavac  
Bruce G. Horowitz  
Wayne E. Johnson  
Sharad C. Khamamkar  
Alan L. Lamb  
Glenn Latimer  
Dan S. Levin  
Gary J. Markle  
José A. Marrero  
James A. McDowall  
Joseph F. Montalbano  
Arne O. Nilsson  
Donald Ogden  
Bansi Patel  
Bradford M. Radimer

Thomas E. Ruhlmann  
William T. Rutledge  
Saba N. Saba  
Amiya Samanta  
Victor W. Sokolski  
Edward C. Stallings  
James E. Staudacher  
Frank L. Tarantino  
George Tsouderos  
Kurt W. Uhler  
Lesley Varga  
Steve Vechy  
Peter J. Vivona  
Graham Walker  
Michael C. Weeks  
Walter A. Wylie

\*Task Leader

This recommended practice was endorsed by Battery Council International (BCI) on April 30, 1995.

The following persons were on the balloting committee:

L. D. Boydston  
R. O. Bylin  
E. F. Chelotti  
R. S. Coleman  
H. R. Davis  
D. Diamant  
G. Engmann  
W. W. Fields  
J. H. Gurney  
K. Hancock

R. D. Handel  
J. D. Hurley  
J. H. Jones  
D. L. Kornegay  
P. R. H. Landrieu  
J. E. LeClair  
G. L. Luri  
J. T. Madill  
O. P. Malik  
O. S. Mazzoni

D. R. McCabe  
M. W. Migliaro  
C. R. Pope  
B. M. Radimer  
J. R. Ribeiro  
E. P. Rothong  
K. H. Sebra  
J. E. Stoner, Jr.  
T. R. Whittemore  
J. P. Whooley

The final conditions for approval of this recommended practice were met on January 24, 1995. This recommended practice was conditionally approved by the IEEE Standards Board on December 13, 1994, with the following membership:

**Wallace S. Read, *Chair***  
**Donald C. Loughry, *Vice Chair***  
**Andrew G. Salem, *Secretary***

Gilles A. Baril  
Bruce B. Barrow  
José A. Berrios de la Paz  
Clyde R. Camp  
James Costantino  
Stephen L. Diamond  
Donald C. Fleckenstein  
Jay Forster\*  
Ramiro Garcia

Donald N. Heirman  
Richard J. Holleman  
Jim Isaak  
Ben C. Johnson  
Sonny Kasturi  
Lorraine C. Kevra  
E. G. "Al" Kiener  
Ivor N. Knight  
Joseph L. Koepfinger\*

D. N. "Jim" Logothetis  
L. Bruce McClung  
Marco W. Migliaro  
Mary Lou Padgett  
Arthur K. Reilly  
Ronald H. Reimer  
Gary S. Robinson  
Leonard L. Tripp

\*Member Emeritus

Also included are the following nonvoting IEEE Standards Board liaisons:

Satish K. Aggarwal  
James Beall

Richard B. Engelman  
Robert E. Hebner

Valerie E. Zelenty  
*IEEE Standards Project Editor*

CLAUSE	PAGE
1. Scope .....	1
2. References .....	1
3. Definitions .....	2
4. Maintenance .....	3
4.1 General .....	3
4.2 Safety .....	3
4.3 Inspections .....	4
4.4 Corrective actions .....	5
4.5 State of charge .....	6
5. Test schedule .....	6
5.1 Acceptance .....	6
5.2 Performance .....	6
5.3 Service .....	7
5.4 Modified performance test .....	7
6. Procedure for battery tests .....	7
6.1 Initial conditions .....	7
6.2 Test length .....	7
6.3 Test discharge rate .....	8
6.4 Acceptance, modified performance, and performance tests .....	10
6.5 Determining battery capacity .....	11
6.6 Service test .....	11
6.7 Restoration .....	11
7. Battery replacement criteria .....	12
8. Records .....	12
9. Recycling and disposal .....	12
9.1 Recycling .....	12
9.2 Disposal .....	12
Annex A Specific gravity (Informative) .....	13
Annex B Determining the state of charge when a specific gravity gradient exists (Informative) .....	14
Annex C Float voltage (Informative) .....	15
Annex D Urgency of corrective actions (Informative) .....	16
Annex E Visual inspection parameters of battery installations (Informative) .....	17
Annex F Example methods (Informative) .....	18
Annex G Alternate applications (Informative) .....	24

# IEEE Recommended Practice for Maintenance, Testing, and Replacement of Vented Lead-Acid Batteries for Stationary Applications

## 1. Scope

This recommended practice provides maintenance, test schedules, and testing procedures that can be used to optimize the life and performance of permanently installed, vented lead-acid storage batteries used for standby power applications. It also provides guidance to determine when batteries should be replaced. This recommended practice is applicable to all stationary applications. However, specific applications, such as emergency lighting units and semiportable equipment, may have other appropriate practices and are beyond the scope of this recommended practice.

Sizing, installation, qualification, other battery types, and application are also beyond the scope of this recommended practice.

This recommended practice does not include any other component of the dc system, or surveillance and testing of the dc system, even though the battery is part of that system. Preoperational and periodic dc system tests of chargers and other dc components may require that the battery be connected to the system. Details for these tests will depend on the requirements of the dc system and are beyond the scope of this recommended practice.

## 2. References

This recommended practice shall be used in conjunction with the following publications:

IEEE Std 100-1992, The New IEEE Standard Dictionary of Electrical and Electronics Terms (ANSI).<sup>1</sup>

IEEE Std 308-1991, IEEE Standard Criteria for Class 1E Power Systems for Nuclear Power Generating Stations (ANSI).

---

<sup>1</sup>IEEE publications are available from the Institute of Electrical and Electronics Engineers, 445 Hoes Lane, P.O. Box 1331, Piscataway, NJ 08855-1331, USA.

IEEE Std 323-1983 (Reaff 1990), IEEE Standard for Qualifying Class 1E Equipment for Nuclear Power Generating Stations (ANSI).

IEEE Std 484-1987, IEEE Recommended Practice for Installation Design and Installation of Large Lead Storage Batteries for Generating Stations and Substations (ANSI).

IEEE Std 485-1983, IEEE Recommended Practice for Sizing Large Lead Storage Batteries for Generating Stations and Substations (ANSI).

IEEE Std 494-1974 (Reaff 1990), IEEE Standard Method for Identification of Documents Related to Class 1E Equipment and Systems for Nuclear Power Generating Stations (ANSI).

IEEE Std 535-1986 (Reaff 1994), IEEE Standard for Qualification of Class 1E Lead Storage Batteries for Nuclear Power Generating Stations (ANSI).

IEEE Std 946-1992, IEEE Recommended Practice for the Design of DC Auxiliary Power Systems for Generating Stations (ANSI).

### 3. Definitions

The following definitions apply specifically to the subject matter of this recommended practice. For other definitions, refer to the standards listed in clause 2.

**3.1 acceptance test:** A constant current or power capacity test made on a new battery to determine that it meets specifications or manufacturer's ratings.

**3.2 capacity test:** A discharge of a battery at a constant current or power to a specified terminal voltage.

**3.3 critical period:** That portion of the duty cycle that is the most severe, or the specified time period of the battery duty cycle.

**3.4 duty cycle:** The load currents a battery is expected to supply for specified time periods.

**3.5 equalizing voltage:** The voltage, higher than float, applied to a battery to correct inequalities among battery cells (voltage or specific gravity) that may develop in service.

**3.6 float voltage:** The voltage applied to a battery to maintain it in a fully charged condition during normal operation.

**3.7 modified performance test:** A test, in the "as found" condition, of a battery's capacity and its ability to provide a high-rate, short-duration load (usually the highest rate of the duty cycle) that will confirm the battery's ability to meet the critical period of the load duty cycle, in addition to determining its percentage of rated capacity.

**3.8 performance test:** A constant current or constant power capacity test, made on a battery after it has been in service, to detect any change in the capacity.

**3.9 service test:** A test, in the "as found" condition, of the battery's capability to satisfy the battery duty cycle.

**3.10 terminal connection detail:** Connections made between rows of cells or at the positive and negative terminals of the battery, which may include terminal plates, cables with lugs, and connectors.

**3.11 vented cell:** A cell in which the products of electrolysis and evaporation are allowed to escape to the atmosphere as they are generated. These batteries are commonly referred to as "flooded."

## 4. Maintenance

### 4.1 General

Proper maintenance will prolong the life of a battery and will aid in ensuring that it is capable of satisfying its design requirements. A good battery maintenance program will serve as a valuable aid in maximizing battery life, preventing avoidable failures, and reducing premature replacement. Battery maintenance should be performed by personnel knowledgeable of batteries and the safety precautions involved.

See IEEE Std 484-1987<sup>2</sup> for initial installation requirements.

### 4.2 Safety

The safety precautions listed herein should be followed during battery maintenance. Work performed on batteries should be done only with proper and safe tools and with the protective equipment listed in 4.2.2.

#### 4.2.1 Methods

Work performed on a battery while in service shall use methods to preclude arcing in the vicinity of the battery.

#### 4.2.2 Protective equipment

The following protective equipment shall be available to personnel who perform battery maintenance work:

- a) Goggles and face shields
- b) Acid-resistant gloves
- c) Protective aprons
- d) Portable or stationary water facilities for rinsing eyes and skin in case of contact with acid electrolyte
- e) Bicarbonate of soda, mixed with a ratio of 0.1 kg to 1 liter (1 lb to 1 gal) of water to neutralize acid spillage  
NOTE — The removal and/or neutralization of an acid spill may result in the production of a hazardous waste. The user should comply with appropriate governmental regulations.
- f) Class C fire extinguisher  
NOTE — Some battery manufacturers do not recommend the use of CO<sub>2</sub> Class C fire extinguishers due to the potential of thermal shock on the battery cases.
- g) Adequately insulated tools

#### 4.2.3 Precautions

The following protective procedures shall be observed during maintenance:

- a) Use caution when working on batteries since they represent an electric shock hazard.
- b) Prohibit smoking and open flames, and avoid the chances of arcing in the immediate vicinity of the battery.
- c) Ensure that the load test leads are clean, in good condition, and connected with a sufficient length of cable to prevent accidental arcing in the vicinity of the battery.
- d) Ensure that all connections to load test equipment include short-circuit protection.
- e) Ensure that battery area ventilation is operable.
- f) Ensure unobstructed egress from the battery area.
- g) Avoid the wearing of metallic objects such as jewelry.

---

<sup>2</sup>Information on references can be found in clause 2.

- h) Neutralize static buildup just before working on a battery by having personnel contact nearest effectively grounded surface.
- i) Ensure that all battery monitoring equipment is operational.

### 4.3 Inspections

Implementation of periodic inspection procedures provides the user with information for determining the operability of the battery. The frequency of the inspections should be based on the nature of the application and may exceed that recommended herein. All inspections should be made under normal float conditions. For specific gravity readings to be meaningful, the electrolyte must be fully mixed. This condition is unlikely to exist following a discharge or water addition. Readings should be taken in accordance with the manufacturer's instructions. Refer to the annexes for more information.

#### 4.3.1 General

Inspection of the battery on a regularly scheduled basis (at least once per month) should include a check and record of the following:

- a) Float voltage measured at battery terminals
- b) General appearance and cleanliness of the battery, the battery rack and/or battery cabinet, and the battery area
- c) Charger output current and voltage
- d) Electrolyte levels
- e) Cracks in cells or leakage of electrolyte
- f) Any evidence of corrosion at terminals, connectors, racks, or cabinets
- g) Ambient temperature and ventilation
- h) Voltage, specific gravity, and electrolyte temperature of pilot cell (if used)
- i) Unintentional battery grounds

#### 4.3.2 Quarterly

At least once per quarter, the general inspection should be augmented as follows. Check and record the following:

- a) Specific gravity of 10% of the battery cells
- b) Voltage of each cell and total battery terminal voltage
- c) Temperature of electrolyte of 10% of the battery cells [suggestion: take the temperature of the cells selected in 4.3.2 item a)]

#### 4.3.3 Yearly

At least once each year, the quarterly inspection should be augmented as follows. Check and record the following:

- a) Specific gravity of each cell
- b) Cell condition [This would involve a detailed visual inspection (see annex F for guidelines) of each cell in contrast to the general inspection in 4.3.1. Review the manufacturer's recommendations.]
- c) Cell-to-cell and terminal connection detail resistance (see D.2)
- d) Structural integrity of the battery rack and/or cabinet

#### 4.3.4 Special inspections

If the battery has experienced an abnormal condition (such as a severe discharge or overcharge), an inspection should be made to ensure that the battery has not been damaged. Include the requirements of 4.3.1 through 4.3.3.

## 4.4 Corrective actions

The corrective actions listed in 4.4.1 through 4.4.3 are meant to provide optimum life of the battery. They in themselves will not guarantee that the battery is completely charged at any given time. Annexes A through G provide some technical background for the necessary actions and their timing and provide another more accurate means for determining the state of charge of a battery.

### 4.4.1 Cell/battery problems

The following items indicate conditions that can be easily corrected prior to the next general inspection. Major deviations in any of these items may necessitate immediate action.

- a) When any cell electrolyte reaches the low-level line, water should be added (see A.4). Water quality should be in accordance with the manufacturer's instructions.
- b) If terminal corrosion is noted [see 4.3.1 item f)], clean the visible corrosion off of the terminal and check the resistance of the connection.
- c) If resistance readings obtained in 4.3.3 item c) or 4.4.1 item b) are more than 20% above the installation value or above a ceiling value established by the manufacturer, or if loose connections are noted, retorque and retest. If retested resistance value remains unacceptable, the connection should be disassembled, cleaned, reassembled, and retested. Refer to IEEE Std 484-1987 for detailed procedures. See also D.2 and annex G.
- d) When cell temperatures deviate more than 3 °C (5 °F) from each other during a single inspection, determine the cause and correct the problem. If sufficient correction cannot be made, contact the manufacturer for allowances that must be taken.
- e) When excessive dirt is noted on cells or connectors, wipe with water-moistened clean wiper. Remove electrolyte spillage on cell covers and containers with a bicarbonate of soda solution [using a ratio of 0.1 kg bicarbonate of soda per liter of water (1 lb bicarbonate of soda to 1 gal water)]. Avoid the use of hydrocarbon-type cleaning agents (oil distillates) and strong alkaline cleaning agents, which may cause containers and covers to crack or craze.
- f) When the float voltage measured at the battery terminals is outside of its recommended operating range, it should be adjusted.

### 4.4.2 Equalizing charge

The following items indicate conditions that, if allowed to persist for extended periods, can reduce battery life. They do not necessarily indicate a loss of capacity. Therefore, the corrective action can be accomplished prior to the next quarterly inspection, provided that the battery condition is monitored at regular intervals (not to exceed one week). Note that an equalizing charge normally requires that equalizing voltage be applied continuously for 35–70 h or longer (refer to the manufacturer's instructions). Single cell charging is an acceptable method when a single cell or a small number of cells appear to need equalizing.

- a) An equalizing charge is desirable if individual cell float voltage(s) deviate from the average value by an amount greater than that recommended by the manufacturer. Typical recommendations are  $\pm 0.04$  V for lead-calcium cells and  $\pm 0.02$  V for lead antimony cells.
- b) An equalizing charge should be given if the specific gravity, corrected for temperature, of an individual cell falls below the manufacturer's lower limit (see D.4).
- c) An equalizing charge should be given immediately if any cell voltage is below the manufacturer's recommended minimum cell voltage (see C.1) at the time of inspection.
- d) Periodic equalizing charges are recommended by some manufacturers. This equalizing charge can be waived for certain batteries based on an analysis of the records of operation and maintenance inspections (see clause 8.).

### 4.4.3 Other abnormalities

Correct any other abnormal conditions noted.

NOTE — Refer to the annexes for a more detailed discussion of these abnormalities and the urgency of the corrective actions.

## 4.5 State of charge

The most accurate indicator of return to full charge is a stabilized charging or float current (refer to the annexes). Specific gravity readings may not be accurate when the battery is on charge following a discharge or following the addition of water. When cell design permits, specific gravity reading accuracy can be improved by averaging several readings taken at different levels within a cell.

## 5. Test schedule

The following schedule of tests is used to

- a) Determine whether the battery meets its specification or the manufacturer's rating, or both.
- b) Periodically determine whether the performance of the battery, as found, is within acceptable limits.
- c) If required, determine whether the battery, as found, meets the design requirements of the system to which it is connected.

### 5.1 Acceptance

An acceptance test of the battery (see 6.4) should be made either at the factory or upon initial installation as determined by the user. The test should meet a specific discharge rate and duration relating to the manufacturer's rating or to the purchase specification's requirements.

NOTE — Batteries may have less than rated capacity when delivered. Unless 100% capacity upon delivery is specified, initial capacity can be as low as 90% of rated. This will rise to at least rated capacity in normal service after several years of float operation. (See IEEE Std 485-1983.)

### 5.2 Performance

- a) A performance test of the battery capacity (see 6.4) should be made within the first two years of service. It is desirable for comparison purposes that the performance tests be similar in duration to the battery duty cycle.
- b) Each battery should undergo additional performance tests at five-year intervals until the battery shows signs of degradation as outlined in 5.2 item c).
- c) Annual performance tests of battery capacity should be made on any battery that shows signs of degradation or has reached 85% of the service life expected for the application. Degradation is indicated when the battery capacity drops more than 10% from its capacity on the previous performance test, or is below 90% of the manufacturer's rating. If the battery has reached 85% of service life, delivers a capacity of 100% or greater of the manufacturer's rated capacity, and has shown no signs of degradation, performance testing at two-year intervals is acceptable until the battery shows signs of degradation.
- d) If performance testing is to be used to reflect baseline capacity or benchmark capacity of the battery (the most accurate form of battery trending), then perform requirements a) through f) of 6.1. If performance testing is to be used to reflect maintenance practices as well as trending, then omit requirement a), perform requirement b), but take no corrective action unless there is a possibility of permanent damage to the battery, and perform requirements c) through f) of 6.1. If, on a performance test that is used to reflect maintenance practices, the battery does not deliver its expected capacity, then the test should be repeated after requirements a) and b) of 6.1 have been completed.

### 5.3 Service

A service test of the battery capability (see 6.6) may be required by the user to meet a specific application requirement. This is a test of the battery's ability "as found" to satisfy the battery duty cycle. When a service test is also being used on a regular basis it will reflect maintenance practices. When a battery has degraded to 90% capacity, service testing should be performed on its normal frequency and performance testing should be performed on an annual basis.

### 5.4 Modified performance test

It is permissible to perform a modified performance test if the test's discharge rate envelopes the duty cycle of the service test. The system designer and the battery manufacturer should review the design load requirements to determine if the modified performance test is applicable and to determine the test procedure. Typically this test is a simulated duty cycle consisting of just two rates: the 1 min rate published for the battery or the largest current load of the duty cycle, followed by the test rate employed for the performance test. Since the ampere-hours removed by a rated 1 min discharge represent a very small portion of the battery's capacity, the test rate can be changed to that for the performance test without compromising the results of the performance test.

A modified performance test is a test of the battery capacity and the battery's ability to provide a high-rate, short-duration load (usually the highest rate of the duty cycle). This will often confirm the battery's ability to meet the critical period of the load duty cycle, in addition to determining its percentage of rated capacity. Initial conditions for the modified performance test should be identical to those specified for a service test. A modified performance test can be used in lieu of a service test at any time. If the battery has been sized in accordance with IEEE Std 485-1983, then the battery is acceptable if it delivers a tested capacity of 80% or greater. "Jumpering out" cells is not allowed during a modified performance test.

## 6. Procedure for battery tests

This procedure describes the recommended practice of capacity testing by discharging the battery. All testing should follow the safety requirements listed in 4.2.

### 6.1 Initial conditions

The following list gives the initial requirements for all battery capacity tests except as otherwise noted.

- a) Equalize the battery if recommended by the manufacturer and then return it to float for a minimum of 72 h, but less than 30 days, prior to the start of the test.
- b) Check all battery connections and ensure that all resistance readings are correct for the system [see 4.3.3 item c)].
- c) Record the specific gravity and float voltage of each cell just prior to the test.
- d) Record the electrolyte temperature of 10% or more of the cells to establish an average temperature (suggested every sixth cell).
- e) Record the battery terminal float voltage.
- f) Take adequate precautions (such as isolating the battery to be tested from other batteries and critical loads) to ensure that a failure will not jeopardize other systems or equipment.

### 6.2 Test length

The recommended procedure is to perform a capacity test for approximately the same length of time for which the battery was sized. When the battery is required to supply varying loads for specified time periods (a load duty cycle), the performance test may not substantiate the battery's capability to meet all design loads, particularly if very-high-rate, short-duration loads determine the battery size. See 6.6 for the service test.

### 6.3 Test discharge rate

The discharge rate depends upon the type of test selected. For the acceptance test or performance test, the discharge rate should be a constant current or constant power load equal to the manufacturer's rating of the battery for the selected test length. See 6.6 for the service test discharge rate.

NOTE — To determine the proper discharge parameters, the test discharge current or power rate is divided by the temperature correction factor as specified by Table 1 for the initial electrolyte temperature. Table 1 can be used for all values of specific gravity for flood cells.

**Table 1 – Temperature correction factors**

Initial temperature		Temperature correction factor
(°C)	(°F)	
-3.9	25	1.520
-1.1	30	1.430
1.7	35	1.350
4.4	40	1.300
7.2	45	1.250
10.0	50	1.190
12.8	55	1.150
15.6	60	1.110
18.3	65	1.080
18.9	66	1.072
19.4	67	1.064
20.0	68	1.056
20.6	69	1.048
21.1	70	1.040
21.7	71	1.034
22.2	72	1.029
22.8	73	1.023
23.4	74	1.017
23.9	75	1.011
24.5	76	1.006
25.0	77	1.000
25.6	78	0.994
26.1	79	0.987
26.7	80	0.980
27.2	81	0.976
27.8	82	0.972
28.3	83	0.968
28.9	84	0.964
29.4	85	0.960
30.0	86	0.956
30.6	87	0.952
31.1	88	0.948

Initial temperature		Temperature correction factor
(°C)	(°F)	
31.6	89	0.944
32.2	90	0.940
35.0	95	0.930
37.8	100	0.910
40.6	105	0.890
43.3	110	0.880
46.1	115	0.870
48.9	120	0.860
51.7	125	0.850
NOTE — This table is based on nominal 1.210 specific gravity cells. For cells with other specific gravities, refer to the manufacturer. The manufacturers recommend that battery testing be performed between 18.3 °C (65 °F) and 32.2 °C (90 °F).		

#### 6.4 Acceptance, modified performance, and performance tests

Set up a load and the necessary instrumentation to maintain the test discharge rate determined in 6.3.

- a) Disconnect the charging source, connect the load bank to the battery, start the timing, and continue to maintain the selected discharge rate. If the charging source cannot be disconnected, the current being drawn by the load must be increased to compensate for the current being supplied by the charging source to the battery.
- b) Maintain the discharge rate until the battery terminal voltage decreases to a value equal to the minimum average voltage per cell as specified by the design of the installation (e.g., 1.75 Vdc) times the number of cells.
- c) Read and record the individual cell voltages and the battery terminal voltage. The readings should be taken while the load is applied at the beginning of the test, at specified intervals, and at the completion of the test. There should be a minimum of three sets of readings.

##### NOTES:

- 1 — Individual cell voltage readings should be taken between respective posts of like polarity of adjacent cells, so as to include the voltage drop of the intercell connectors.
- 2 — The possibility of a weak cell(s) should be anticipated and preparations should be made for bypassing the weak cell with minimum hazard to personnel for performance testing only.
- d) If one or more cells is approaching reversal of its polarity (+1 V or less) and the test nears the 90–95% expected completion time, continue the test until the specified terminal voltage is reached.
- e) If earlier in the test an individual cell is approaching reversal of its polarity (+1 V or less) but the terminal voltage has not yet reached its test limit, the test should be stopped, and the weak cell should be disconnected from the battery string and bypassed with a jumper of adequate conductor ampacity. The new minimum terminal voltage should be determined based on the remaining cells [see 6.4 item b)]. The test should then be continued in order to determine the capacity of the remaining cells. The time required to disconnect the cell, install the jumper, and restart the test shall not exceed 10% of the total test duration or 6 min, whichever is

shorter. This "downtime" shall not be included in the test discharge period (i.e., the capacity determination shall be based on the actual test time).

NOTE — No more than one "downtime" period should be allowed when a battery is being tested. The battery may supply higher than its normal capacity (especially during short-duration testing) if the battery is subjected to more than one "downtime period."

- f) Observe the battery for intercell connector heating.
- g) At the conclusion of the test, determine the battery capacity according to the procedure outlined in 6.5.

NOTE — If after the test one or more of the reversed cells are replaced, the benchmark capacity of the battery can be reestablished by either retesting the battery or by analysis. If the problem that caused the cell to reverse is identified and corrected, the cell can be reinstalled into the battery and the battery can be retested to establish the benchmark capacity, or the cell can be discharged independently, recharged, reinstalled into the bank, and the benchmark capacity reestablished by analysis.

## 6.5 Determining battery capacity

For an acceptance or performance test, the following equation should be used to determine the battery capacity:

$$\% \text{ capacity at } 25^{\circ}\text{C (77}^{\circ}\text{F)} = [T_a/T_s] \cdot 100$$

where

$T_a$  is actual time of test to specified terminal voltage [see 6.4 item b)]  
 $T_s$  is rated time to specified terminal voltage

## 6.6 Service test

A service test is a special battery capacity test that may be required to determine if the battery will meet the battery duty cycle of the dc system (see 5.3). The system designer should establish the test procedure and acceptance criteria prior to the test. The battery should be tested in its "as found" condition and the test should not be corrected for temperature or age. If the battery was sized in accordance with IEEE Std 485-1983, the margins added for temperature ranges, load growth, and aging will provide adequate battery capacity to meet the battery duty cycle throughout its service life. Trending battery voltage during the critical periods of the load duty cycle will provide the user with a means of predicting when the battery will no longer meet design requirements. If the system design changes, sizing (IEEE Std 485-1983) will have to be reviewed, and the service test will have to be modified accordingly. Successful test results can be used to evaluate battery performance and degradation. The recommended procedure for the test is:

- a) The initial conditions shall be as identified in 6.1 [omit requirement a), perform requirement b) but take no corrective action unless there is a possibility of permanent damage to the battery, and perform requirements c) through f)].
- b) The discharge rate and test length should correspond as closely as is practical to the battery duty cycle.  
 NOTE — At times the battery duty cycle may be reevaluated per IEEE Std 485-1983 in order to remove conservatism used in sizing the battery.
- c) If the battery does not meet the duty cycle, review its rating to see if it is properly sized; equalize the battery, and, if necessary, inspect the battery as discussed in 4.3; take necessary corrective actions; and repeat the service test. A battery performance test (see 5.2) may also be required to determine whether the problem is the battery or the application.

## 6.7 Restoration

Disconnect all test apparatus. Recharge the battery and return it to normal service.

## 7. Battery replacement criteria

The recommended practice is to replace the battery if its capacity as determined in 6.5 is below 80% of the manufacturer's rating if the battery was sized using a 1.25 aging factor. If a lesser aging factor was used, battery replacement will be required before 80% capacity is reached to ensure that the load can be served (consult the battery manufacturer). The timing of the replacement is a function of the sizing criteria utilized and the capacity margin, compared to the load requirements available. Whenever replacement is required, the recommended maximum time for replacement is one year. A capacity of 80% shows that the battery rate of deterioration is increasing even if there is ample capacity to meet the load requirements. Other factors, such as unsatisfactory battery service test results (see 6.6), require battery replacement unless a satisfactory service test can be obtained following corrective actions.

Physical characteristics, such as plate condition together with age, are often determinants for complete battery or individual cell replacements. Reversal of a cell as described in 6.4 step d) is also a good indicator for further investigation into the need for individual cell replacement. Replacement cells, if used, should be compatible with existing cells and should be tested prior to installation. The capacity of replacement cell(s) should not degrade the battery's existing ability to meet its duty cycle. Replacement cells are not usually recommended as the battery nears its end of life.

Failure to hold a charge, as shown by cell voltage and specific gravity readings, is a good indicator for further investigation into the need for battery replacement.

When disposing of a battery, refer to applicable regulations and laws.

## 8. Records

Data obtained from inspections and corrective actions are important to the operation and life of the batteries. Data such as indicated in 4.3 should be recorded at the time of installation and as specified during each inspection. Data records should also contain reports on corrective actions (see 4.4) and on capacity and other tests indicating the discharge rates, their duration, and results.

It is recommended that forms be prepared to record all data in an orderly fashion and in such a way that comparison with past data is convenient. For a suggested format, see IEEE Std 323-1983, clause 8. A meaningful comparison will require that all data be converted to a standard base in accordance with the manufacturer's recommendations.

## 9. Recycling and disposal

All batteries have a useful life and eventually must be either repaired or scrapped. When a lead-acid battery must be scrapped, it shall be disposed of in a proper fashion.

### 9.1 Recycling

Lead-acid batteries can be fully recycled. Seek advice from the battery manufacturer on how to proceed with battery recycling.

### 9.2 Disposal

When a battery is to be disposed of, the governmental regulations for such disposal should be followed.

The local hazardous waste management agency can give information on how to proceed with respect to treatment, storage, disposal, facility standards, and applicable permitting procedures.

## **Annex A Specific gravity (Informative)**

### **A.1 Effect of charging**

During the recharge of a battery, high-specific-gravity sulfuric acid is generated. This acid will sink toward the bottom of the cell, resulting in a specific gravity gradient that produces a low reading at the top of the cell that is not representative of the average specific gravity. Therefore, it is normal for the state of charge as indicated by the specific gravity of electrolyte at the top of the cell to lag behind the state of charge that is indicated by the ampere-hours returned to the battery indicated by reduced current to the battery on recharge. Charging voltage limits do not ordinarily allow enough recharge current to provide mixing action. Therefore, this gradient may persist until corrected by diffusion.

### **A.2 Effect of temperature**

Specific gravity readings are based on a temperature of 77 °F (25 °C). The readings should be corrected for the actual electrolyte temperature and level (see A.3). For each 3 °F (1.67 °C) above 77 °F, add 1 point (0.001) to the reading. Subtract 1 point for each 3 °F below 77 °F.

### **A.3 Effect of electrolyte level**

The specific gravity of the electrolyte in a cell will increase with a loss of water due to electrolysis or evaporation. When specific gravity readings are being taken, the electrolyte levels should also be measured and recorded. The battery manufacturer will provide a gravity correction factor for the particular cells involved. However, if the electrolyte level is between the high and low level marks and the temperature corrected specific gravity of the electrolyte is within the manufacturer's nominal specific gravity range, it is not necessary to correct the specific gravity of the battery for electrolyte level.

The apparent electrolyte level depends on the charging rate because gas generated during charging causes an apparent expansion of the electrolyte. If the electrolyte is at or near the high-level mark at float voltage, it may rise above that mark on charge. This condition is not objectionable. It does dictate, however, that electrolyte level readings should be made only after the battery has been at float voltage for at least 72 h.

### **A.4 Effect of water additions**

When water is added to a cell, it tends to float on top of the electrolyte because its specific gravity is 1.000 in comparison to 1.215 nominal for the electrolyte in most batteries. If the cells are in a normal float charge condition, there is very little mixing of the electrolyte due to gassing. In certain cell types it may take 6–8 weeks or longer for complete mixing to occur. The specific gravity should be read before adding water, or the battery should be given an equalizing charge after the water has been added. The battery should be back on normal float voltage for 72 h before the specific gravity is measured after an equalizing charge.

## **Annex B Determining the state of charge when a specific gravity gradient exists (Informative)**

The pattern of charging current delivered by a conventional voltage-regulated charger after a discharge is the most accurate method for determining the state of charge. As the cells approach full charge, the battery voltage rises to approach the charger output voltage, and the charging current decreases. When the charging current has stabilized at the charging voltage, the battery is charged, even though specific gravities have not stabilized.

Specific gravity readings may not be accurate when the battery is on charge following a discharge or following the addition of water (highest electrolyte specific gravity at the bottom of the cell, lowest at the top). When cell design permits, specific gravity reading accuracy can be improved by taking readings at the top, middle, and bottom of the cell. The average of these three readings should counteract the stratification of the electrolyte and reflect the actual specific gravity of the electrolyte of the cell.

If the charging voltage has been set at a value higher than normal float voltage (so as to reduce charging time), it is normal practice to reduce the charging voltage to a float value after the charging current stabilizes. The float current will soon stabilize, even though the specific gravity readings at the top of the cell continue to increase.

NOTE — Refer to the manufacturer's instructions for time periods to maintain charging voltages after current stabilization.

## **Annex C Float voltage (Informative)**

### **C.1 Low-voltage cells**

Cell voltage is not, by itself, an indication of the state of charge of the battery. Prolonged operation of cells below 2.13 V (typical for nominal 1.215 specific gravity cells) can reduce the life expectancy of cells. If normal life is to be obtained from these cells, they should be given an equalizing charge. (Consult the manufacturer for the proper voltage values for other values of specific gravity.)

NOTE — A cell voltage of 2.07 V (typical for nominal 1.215 specific gravity cells) or below under float conditions and not caused by elevated temperature of the cell indicates internal cell problems and may require cell replacement. (Consult the manufacturer for the proper voltage values for other values of specific gravity.)

### **C.2 High-voltage cells**

There is no detrimental effect associated with a cell that has a float voltage higher than the average of the other cells in the battery except for the extreme case where the cell potential equals or exceeds the gassing potential [2.38 V at 25 °C (77 °F)]. If an equalizing charge is given to the battery, the float voltage of the other cells will be increased, and the float current will be decreased. This decrease will lower the voltage of the high cell.

NOTE — This condition can also exist when a few new cells are added to an old battery as replacements.

### **C.3 Effect of temperature**

As the temperature of the electrolyte increases, internal resistance decreases and the charging current increases in order to maintain a constant cell voltage. Therefore, cells in a battery at a higher temperature than the other cells will require higher current. However, as the cells are in series, the current is determined by the charger voltage and the average temperature of the battery. The voltage of the warmer cells will be lower than the average.

If a warmer cell's voltage is below 2.13 V, its temperature-corrected voltage can be determined by adding 0.005 V for each degree Celsius (0.003 V/ °F) that the cell temperature is above the average temperature of the other cells. If the cell voltage is less than 2.13 V after being corrected for the effects of temperature, an equalizing charge is required. An effort should be made to eliminate the cause of the temperature differential (see C.1 and D.3).

When all cells are at some higher temperature, the charging current under normal float conditions will automatically increase to hold the required float voltage. However, individual cell voltages will not be affected and no correction for temperature will be necessary.

## **Annex D Urgency of corrective actions (Informative)**

### **D.1 Adding water**

For capacity, the addition of water is not urgent unless the tops of the plates are in danger of being exposed. However, for safety, if flame-arresting vents are provided, water should be added before the electrolyte level reaches the bottom of the funnel stem. Electrolyte levels above the high-level line will not affect safety or capacity unless the cell reaches an electrolyte overflow condition.

If the level of electrolyte has dropped low enough to expose plates, check the specific gravity where possible and then add water to at least the low-level line. If visual inspection shows no evidence of leakage, then equalize and test in accordance with the manufacturer's recommendation.

### **D.2 Connection resistance**

It is good practice to read and record intercell and terminal connection detail resistances as a baseline upon installation as recommended by IEEE Std 484-1987. It is very important that the procedure be consistent so as to detect upward changes that could be caused by corrosion or loose connections. Increased resistance is a cause for concern and may require corrective action.

Normal connection resistance varies with the cell size and connection type (e.g., from less than 10  $\mu\Omega$  for a large battery to as much as 100  $\mu\Omega$  for a smaller battery). Methods for taking these readings include use of digital low-resistance ohmmeters or measurement of millivolt drop during capacity testing. The manufacturer should be contacted for the expected values. It is customary to use either a 20% change in the previously established baseline value or a value exceeding the manufacturer's recommended limit as a criteria for initiation of corrective action prior to the next inspection. The timing of corrective actions should be determined by an analysis of the effects of the increased resistance. See annex G for suggested methods of measuring connection resistances.

NOTE — Every time all battery connections are cleaned and reassembled, a new baseline can be established if the new measured values are consistent with the initially installed values.

### **D.3 Cell temperature**

Large cell-temperature deviations are usually caused by shorting conditions, which are also evident by the cell voltage. This is cause for immediate cell replacement. All other temperature deviations are usually caused by outside conditions that are part of the installation [see IEEE Std 484-1987, subclause 5.1.1(5)]. While operation at elevated temperatures will reduce life expectancy, it will not adversely affect capacity.

### **D.4 Equalizing charge**

When an individual cell voltage corrected for temperature is below 2.13 V (typical for nominal 1.215 specific gravity cells), corrective action should be initiated immediately. It can be accomplished by providing an equalizing charge to the entire battery. However, it is often more convenient to apply the equalizing charge to the individual cell. This may be done during normal float operation of the battery.

## Annex E Visual inspection parameters of battery installations (Informative)

The following is a list of visual parameters that can be used to inspect a battery while it is in service. It is important that all abnormalities and all other observations made during the inspection (whether good or bad) be recorded. This information can be used for trending purposes in the future.

- a) Inspect the battery rack for rusting, corrosion, and other deterioration that could affect the battery rack structural integrity and strength and inspect approximately 10% of the battery rack fasteners for tightness.
- b) Perform the following steps, where applicable, for seismic installations.
  - 1) Inspect the battery to ensure that an intercell spacer is present between each battery jar.
  - 2) Inspect the intercell spacers in place for deterioration (broken, warped, crumbling, etc.).
  - 3) Verify that the space between each of the end-rails and the "end" battery jars is  $\leq$  to 3/16 in or a value specified by the manufacturer.
- c) Verify that the rail insulators are in place and in good condition.
- d) Verify that the electrolyte level of each cell is between the high and low level marks imprinted on the cell case.
- e) Inspect each battery cell jar, cell jar cover, and seal (jar-to-cover seal, post-to-cover seal) for deterioration (cracking, crazing-spiderweb effect, distortion, etc.).
- f) Examine the plates in each cell for sulphation.
 

NOTE — Sulphation can sometimes be detected on the plate edges by shining a light source on the plates; the light will reflect off the yellowish sulphate crystals.
- g) Examine the plates in each cell for the proper color that indicates a fully charged battery based on the manufacturer's information.
 

NOTE — Normally, fully charged positive plates are colored a deep chocolate-brown color. Negative plates are normally a medium grey. A horizontal ring of white deposits around the plates and on the inside of the jar indicates "hydration" due to a completely discharged battery. Consult the manufacturer's maintenance instructions for further guidelines in this area. If any negative plates are reddish in color, this indicates copper contamination, and the cell should be replaced as soon as practical.
- h) Examine, if possible through the clear battery jar case, the plates, the bus bar connection to each plate, and the bus bar connection to the post of each battery cell for corrosion and other abnormalities. Inspect the lower part of the post seals and the underside of the cover for cracking or distortion.
- i) Examine the cell plates, spacers, and sediment space of each cell to determine if any deterioration (warped plates and spacers, lifted cell posts, pieces of plate material that have fallen off, shorted plates, excessive sediment in the bottom of the cell, plates that have dropped lower than the other plates, etc.) has occurred that could affect a cell relative to the rest of the cells in the battery.
- j) Examine the cell posts of each cell to determine if any of them have "grown" or lifted to a larger degree than the rest of the posts of the battery.
 

NOTE — The positive plates of lead-acid batteries normally swell or "grow" with age and use. Most manufacturers claim that 5% growth is the expected maximum limit during the life of the battery.
- k) Inspect each electrical cell-to-cell and terminal connection to ensure that they are clean (no significant corrosion or foreign matter) and coated with anti-corrosion material.
 

NOTE — Unless corrosion is cleaned off of battery terminals periodically, it will spread into the area between the posts and the connectors.
- l) Verify that all cells of the battery are properly numbered.
- m) Verify that each battery cell vent, flame arrestor, and dust cap is present and inspect each for damage.
- n) Examine the general condition of the battery, battery rack and/or cabinet, and battery room to determine if they are clean and in good order.

## Annex F Example methods (Informative)

The following are examples of how to take intercell detail connection resistance measurements for a variety of available battery designs. Other battery designs and methods of taking resistance readings are also used but are not specified in this annex. It is important to select a method for a particular battery design and use the same method consistently for trending purposes.

### F.1 Recommended method for performing detail connection resistance readings using a micro-ohmmeter

- a) When taking micro-ohmmeter readings, the probes should be held perpendicular to the battery post.
- b) Set the micro-ohmmeter scale to the lowest resistance scale.
- c) **DO NOT TAKE A READING ACROSS THE CELL.** This reading could damage the meter.
- d) When performing micro-ohmmeter readings, it is recommended that these readings be taken from the battery post to the battery post of connected cells, or from the battery post to the terminal lug.

NOTE — It is not acceptable to record the microohm readings in milliohms. All readings must be converted into microohms.

The proper and improper methods of performing detailed connection resistance readings are shown in figures F.1a) and F.1b), respectively.

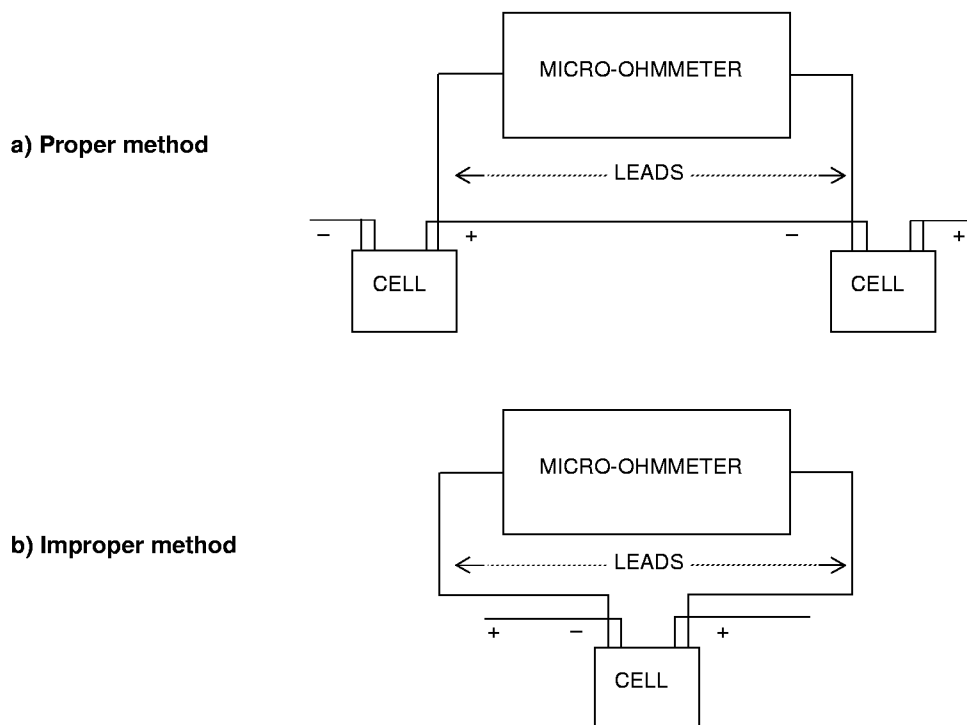

Figure F-1—Detailed connection resistance measurement

## F.2 Recommended method for single intercell connections and parallel-post intercell connections

- a) Measure the intercell connection resistance of each intercell connection by measuring from the positive terminal post to the negative terminal post of the adjacent cell.
- b) Record the measurements.

NOTE — Single intercell connections and parallel-post intercell connections detail connection resistance measurements are treated in the same manner.

Figure F-2 shows a typical single intercell connection. Figure F-3 shows a typical parallel-post intercell connection.

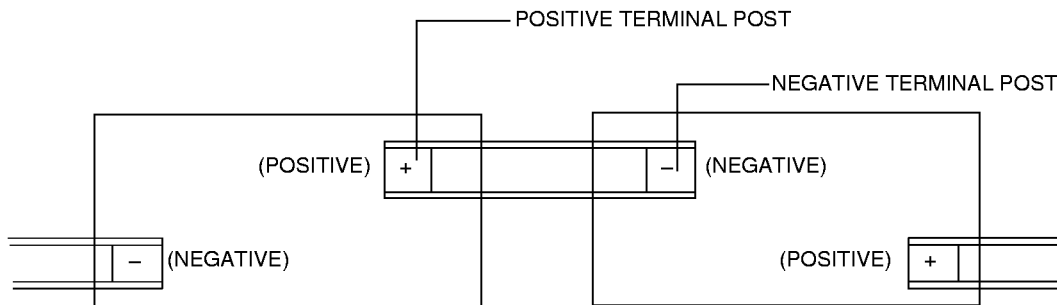

**Figure F-2—Single intercell connection (typical)**

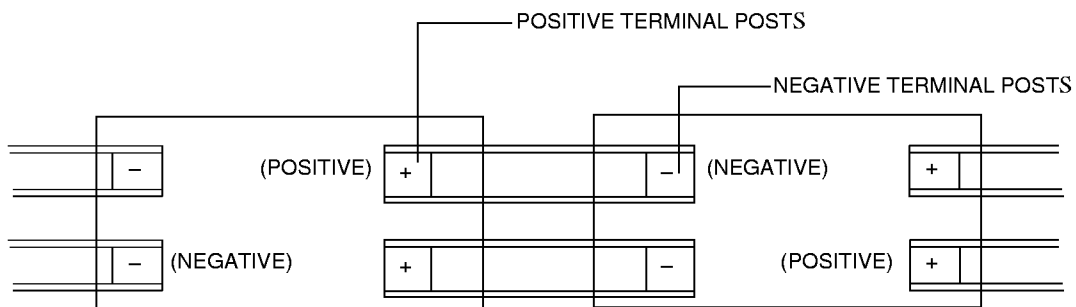

**Figure F-3—Parallel-post intercell connection (typical)**

## F.3 Recommended method for double-post intercell connections

- a) Measure the intercell connection resistance of each intercell connection by measuring from:
  - 1) Terminal post A to terminal post C
  - 2) Terminal post B to terminal post D
- b) Record the measurements.

NOTE — The resistance of intertier and interrack connections, with or without connection plates, can be performed using steps a) and b) above.

Figure F-4 shows a typical double-post intercell connection.

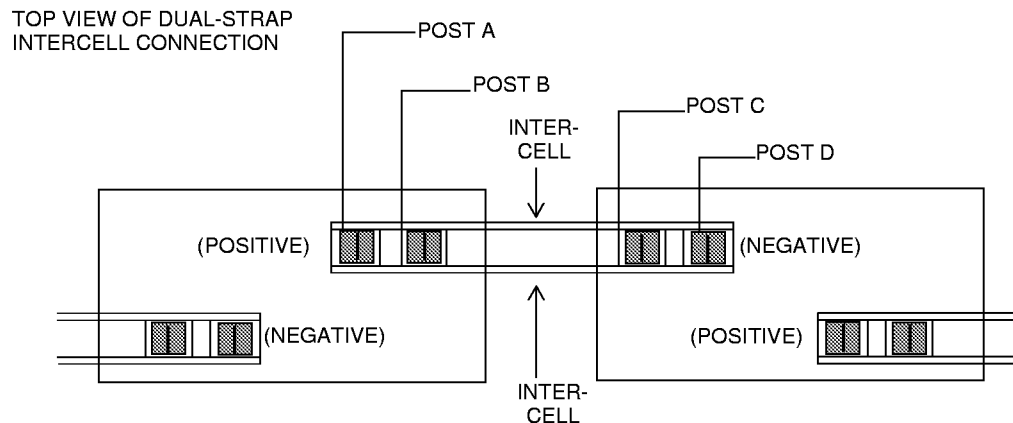

**Figure F-4—Double-post intercell connection (typical)**

#### F.4 Recommended method for triple-post intercell connections

- a) Measure the intercell connection resistance of each intercell connection by measuring from:
  - 1) Terminal post A to terminal post D
  - 2) Terminal post B to terminal post E
  - 3) Terminal post C to terminal post F
- b) Record the measurements.

NOTE — The resistance of intertier and interrack connections, with or without connection plates, can be performed using steps a) and b) above.

Figure F-5 shows a typical triple-post intercell connection.

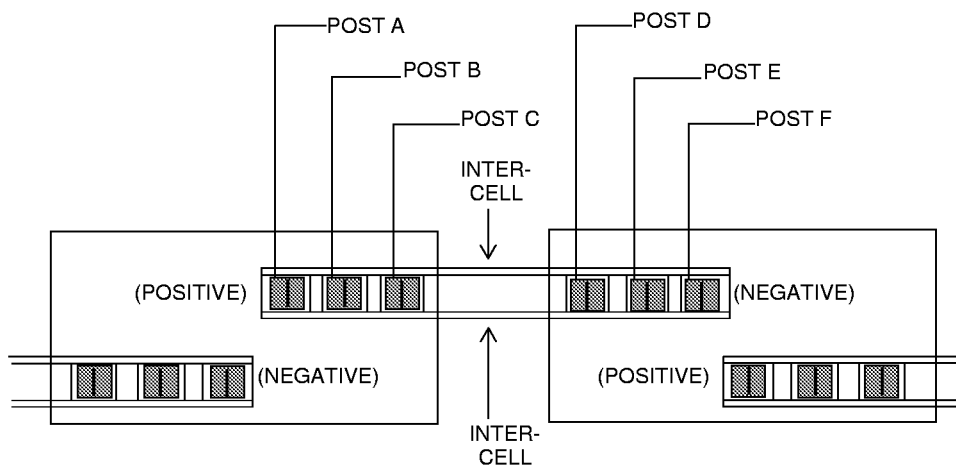
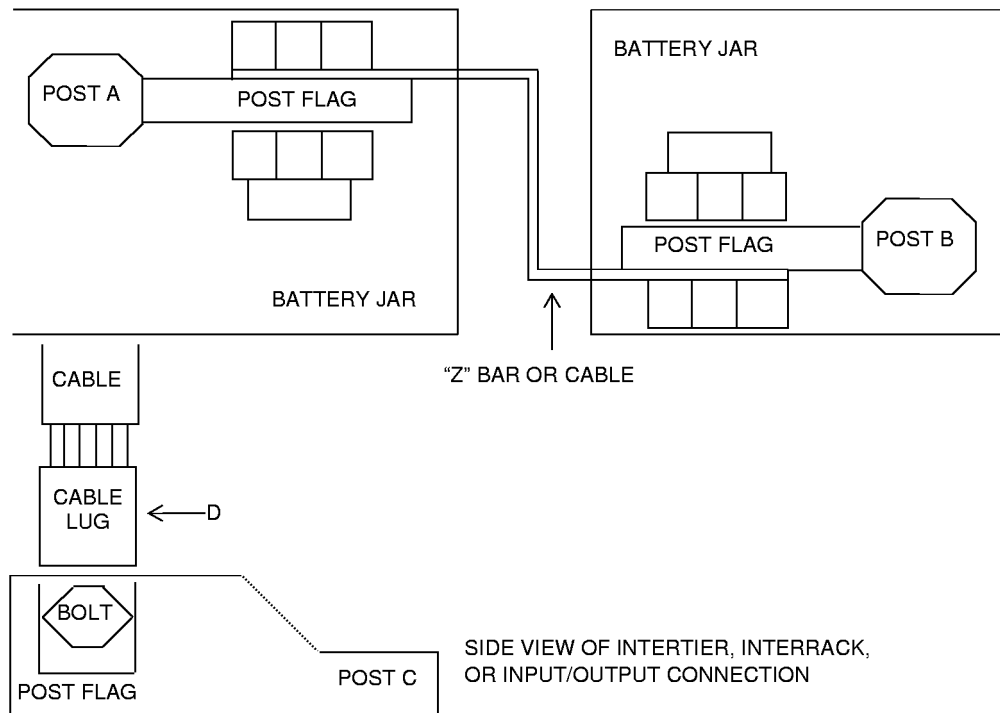

**Figure F-5—Triple-post intercell connection (typical)**

### F.5 Recommended method for flag-post intercell connections

- Measure the connection resistance of the intercell connections from terminal post A to terminal post B.
- Measure the connection resistance of the intertier and interrack connections from terminal post A to terminal post B and/or from terminal post A to terminal lug A and terminal post B to terminal lug B.
- Measure the connection resistance of the terminal connections from terminal post C to terminal lug D on the connecting cable.
- Record the measurements.

Figure F-6 shows typical flag-post terminal connections.

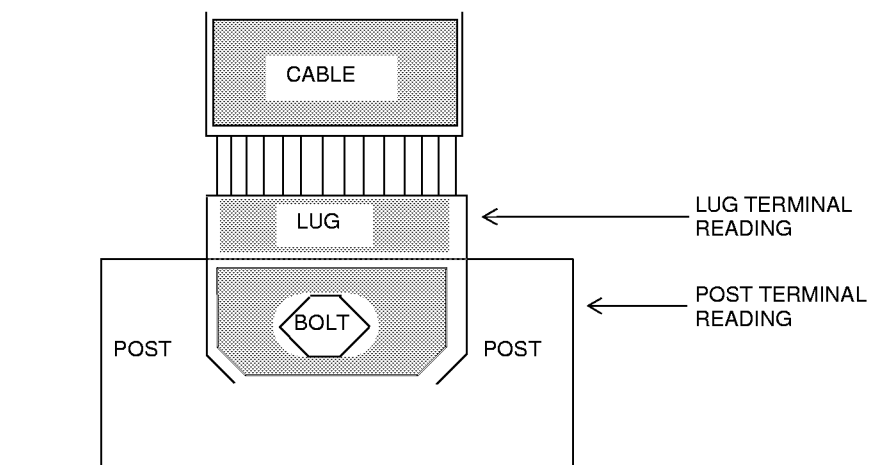

**Figure F-6—Flag-post terminal connections (typical)**

### F.6 Recommended method for single connections

- Measure the connection resistance of single terminal connections by measuring from terminal lug to terminal post.
- Record the measurements.

Figure F-7 shows a typical single terminal connection.

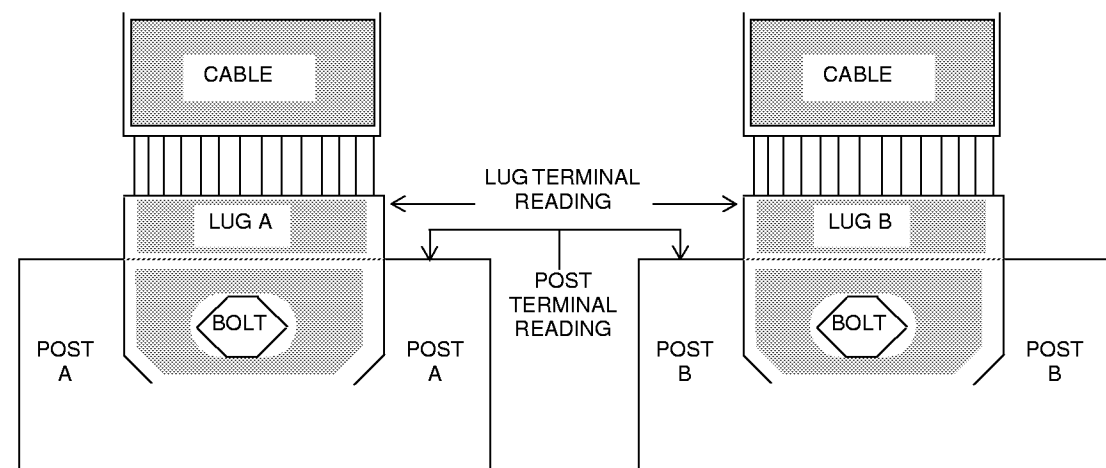

**Figure F-7—Single terminal connection (typical)**

### F.7 Recommended method for multiple terminal connections

- a) Measure the connection resistance of each terminal connection by measuring from:
  - 1) Terminal lug A to terminal post A
  - 2) Terminal lug B to terminal post B
- b) Record the measurements.

Figure F-8 shows a typical multiple terminal connection.



**Figure F-8—Multiple terminal connection (typical)**

## F.8 Recommended method for cable, plate, and post connections

- a) Measure the terminal connection resistance of each terminal connection by measuring from:
  - 1) Terminal lug A to terminal post A
  - 2) Terminal lug B to terminal post A
  - 3) Terminal lug C to terminal post B
  - 4) Terminal lug D to terminal post A
  - 5) Terminal lug E to terminal post B
  - 6) Terminal lug F to terminal post B
- b) Record the measurements.

NOTE — The resistance of intertrack connections and terminal connections will be performed using steps a) and b) above.

Figure F-9 shows cable, plate, and post connections.

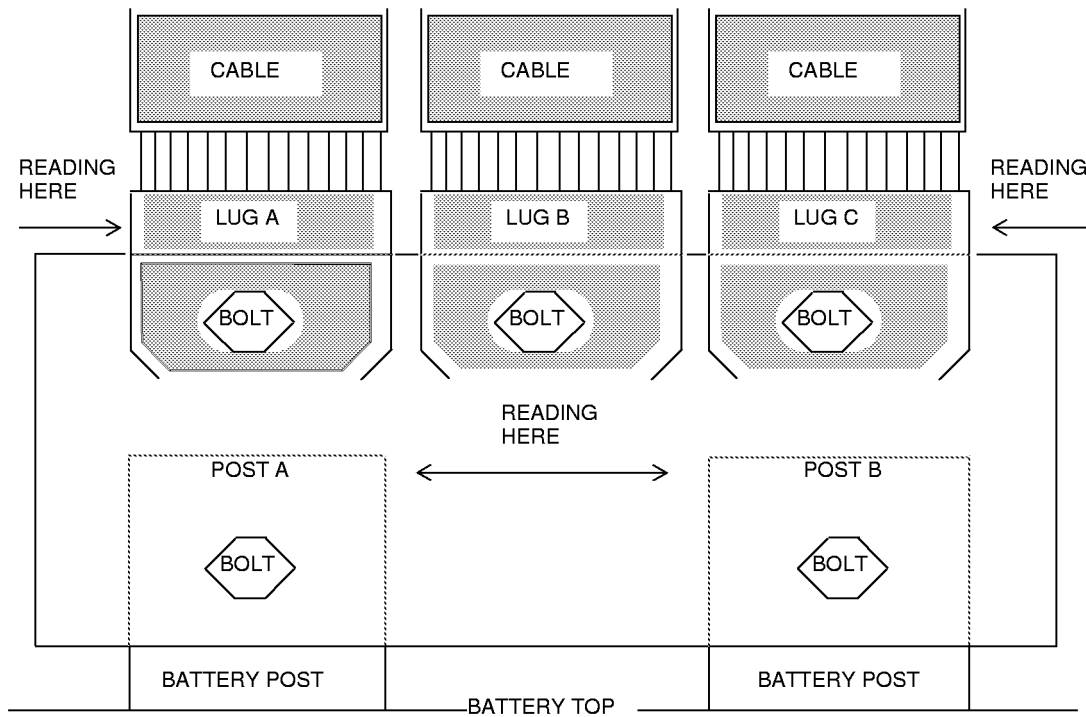

NOTE—Lug on the other side of plate from Lug A is marked as Lug D, Lug B as Lug E, and Lug C as Lug F.

**Figure F-9—Cable, plate, and post connections**

## **Annex G Alternate applications (Informative)**

As outlined in 4.3, periodic inspections and subsequent corrective actions are intended to provide a properly maintained battery that will meet its performance requirements. The performance and service tests outlined in 5.2 and 5.3 can be used to demonstrate the adequacy of the maintenance practices. Each of these recommended practices of inspections and tests should be used as best suited for the particular needs of the application. It is the user's responsibility to format the maintenance, inspection, and testing program to optimize the benefits available.

All of this recommended practice need not apply in all situations. For example, on some small battery installations (such as substations), some users perform a short high-rate discharge test that can be accomplished without removing the battery from service. Tests of this nature can provide a useful indication of the battery's capability to perform its design function and will reduce the need for some other inspections and tests.